

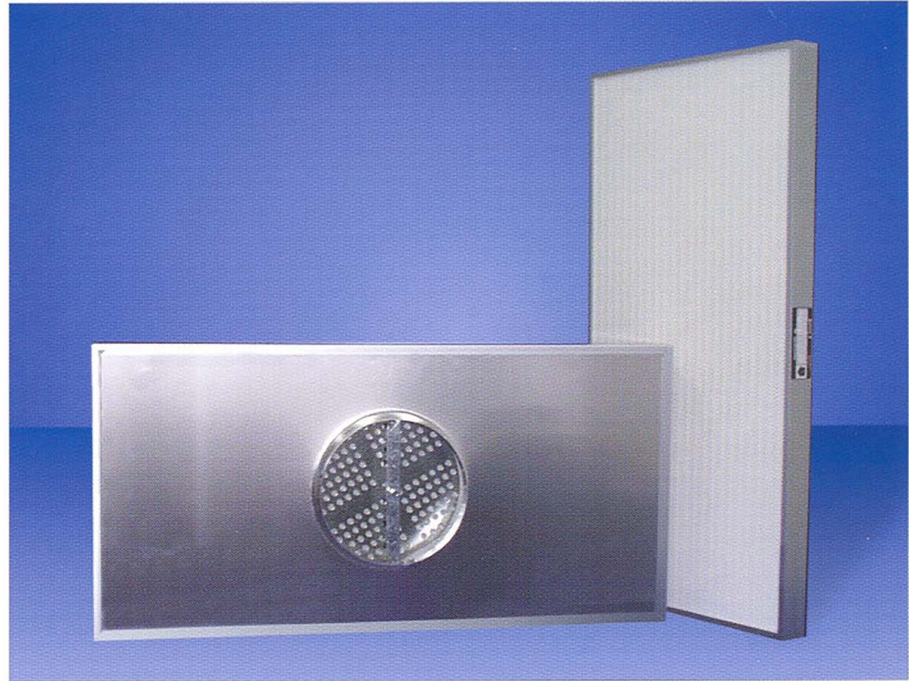

Vilair™ Disposable Ceiling Module

Hermetically Sealed Ceiling Module

- Hermetically sealed construction
- Low profile, lightweight housing
- True High efficiency filter
- Leak and/or scan test



The Vilair™ Disposable Ceiling Module is designed for optimum filter performance with an individually ducted system for use in laminar and non-laminar flow cleanroom Class 100,000 to 10.

The Vilair™ Disposable Ceiling Module is hermetically sealed to prevent voids and leaks to meet stringent air quality requirements of cleanrooms. It is typically installed in a T-Bar grid system suspended from the ceiling or installed in an Vilair modular ceiling grid. Hold-down clamping is not required.

Its low profile, lightweight, and disposable design makes it ideal for use in hospital operating theatres and laboratories, pharmaceutical, microelectronic, film and optical fiber facilities, food processing plants and other applications where airborne contaminants must be carefully controlled.

Hermetically Sealed Construction

The Vilair™ Disposable Ceiling Module is hermetically sealed and tested to prevent leakage between hood inlet and air leaving side. All metal to metal joints are bonded to eliminate bypass leakage.

The standard module comes with a 250mm (10") diameter inlet, a fixed distribution plate, an integral round duct connection and a white epoxy coated faceguard on the downstream side to protect the HEPA mini-pleat pack.

Low Profile and Lightweight Housing

The Vilair™ Disposable Ceiling Module is made of lightweight anodized extruded aluminum. The low profile and lightweight of the Vilair™ Disposable Ceiling Module helps to reduce handling and installation time.

True High Efficiency Filter

The Vilair™ filter is made of water-resistant and fire retardant glass fiber media.

Choose from two types of true high efficiency filters :

H14 HEPA Filter - 99.999% minimum efficiency on 0.3 μm particles.

U15 ULPA Filter - 99.9995% minimum efficiency on 0.12 μm particles.

Leak and/or Scan Test

All HEPA filters are leak tested. ULPA filters are scanned with a laser spectrometer with PSL particles for leaks, and tested for efficiency and air distribution.



Vilair TM Disposable Ceiling Module

Specifications

Standard	
Operating Temperature :	70°C (158°F)
Housing :	Anodized aluminum extrusion, standard profile
Gasket :	No gasket
Faceguard Location :	Air leaving side
Media :	H14 HEPA Filter (99.999% efficiency on 0.3 µm particles)
Options	
	: U15 ULPA Filter (99.9995% efficiency on 0.12 µm particles)
	Flat profile, closed cell neoprene gasket on air leaving side
	Eliminate faceguard
	Divider and volume control damper
	Adjustable distribution plate with divider
	300mm (12") inlet collar

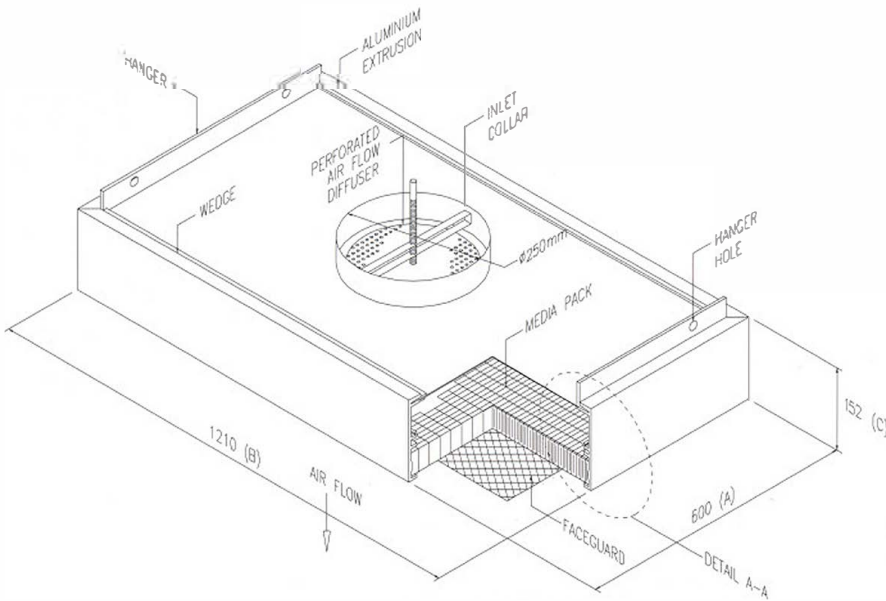

Isometric View

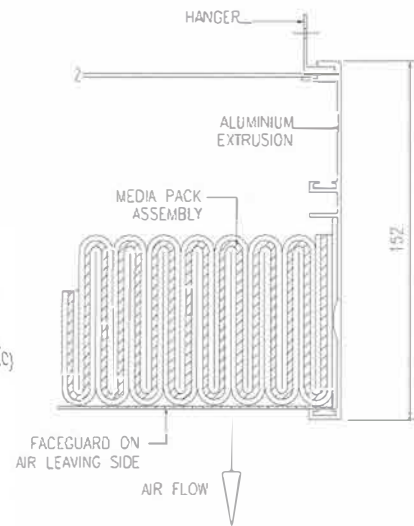

A-A View

Product Information

Size in mm			Nominal Airflow		Initial Resistance @ 0.45 m/s			
A	B	C	@ 0.45 m/s		H14 (HEPA)		U15 (ULPA)	
			(m ³ /h)	(m ³ /s)	(In. W.G.)	(Pa)	(In. W.G.)	(Pa)
600	600	152	600	0.166	0.50	125	0.58	145
600	915	152	900	0.250	0.50	125	0.58	145
600	1210	152	1200	0.333	0.50	125	0.58	145
600	600	175	600	0.166	0.32	80	0.36	90
600	915	175	900	0.250	0.32	80	0.36	90
600	1210	175	1200	0.333	0.32	80	0.36	90

- Note :**
- 1) Standard inlet collar is Ø250mm (10").
 - 2) Other sizes and specifications are available upon request. (Maximum size 610mm x 1220mm)
 - 3) Recommended final resistance : 1.6" W.G./400Pa.
 - 4) Add 15 Pa to initial resistance for Module Construction.
 - 5) Add 50mm(1.97") for collar height.



Vilair has a policy of continuous product research and improvement and reserves the right to change design and specifications without notice.



Cert No. Q5643